

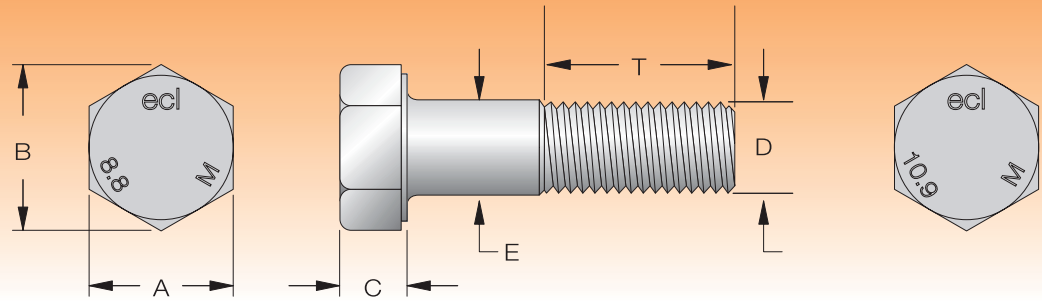

METRIC HEXAGON BOLTS



AS/NZS 1110-1995 • AS112-1980 • PRODUCT DIMENSIONS • METRIC COARSE

D Diameter	Metric Course		A Across Flats			B Across Corners Max	C Head Height Nom	E Shank Diameter	
	Pitch		Max	Up to 150mm	Over 150mm			Max	Min
	Mm	Tap Drill		Min	Min				
M5	0.80	4.20	8.0	7.78	7.64	9.2	3.5	5.0	4.82
M6	1.00	5.00	10.0	9.78	9.64	11.5	4.0	6.0	5.82
M8	1.25	6.80	13.0	12.73	12.57	15.0	5.3	8.0	7.78
M10	1.50	8.50	16.0	15.75	15.27	18.4	6.4	10.0	9.78
M12	1.75	10.20	18.0	17.73	17.57	20.7	7.5	12.0	11.73
M14	2.00	12.00	21.0	20.67	20.16	24.2	8.8	14.0	13.73
M16	2.00	14.00	24.0	23.67	23.16	27.7	10.0	16.0	15.73
M18	2.50	15.50	27.0	26.67	26.16	31.2	11.5	18.0	17.73
M20	2.50	17.50	30.0	29.67	29.16	34.6	12.5	20.0	19.67
M22	2.50	14.50	34.0	33.38	33.00	39.3	14.0	22.0	21.67
M24	3.00	21.00	36.0	35.38	35.00	41.6	15.0	24.0	23.67
M27	3.00	24.00	41.0	40.38	40.00	47.3	16.7	27.0	26.67
M30	3.50	26.50	46.0	45.00	45.00	53.1	18.7	30.0	29.67
M33	3.50	24.50	50.0	49.00	49.00	57.7	20.5	33.0	32.61
M36	4.00	32.00	55.0	53.80	53.80	63.5	22.5	36.0	35.61

METRIC FINE

Metric Course		PC 8.8		PC 10.9	
Diam.	Pitch MM	Torque Nm	Bolt Tension kN	Torque Nm	Bolt Tension kN
M5	0.80	5.0	5.35	8.0	7.67
M6	1.00	9.0	7.54	13.0	10.90
M8	1.25	22.0	13.80	32.0	19.80
M10	1.50	44.0	21.90	63.0	31.30
M12	1.75	77.0	31.80	109.0	45.50
M14	2.00	122.0	43.40	174.0	62.10
M16	2.00	190.0	59.20	270.0	84.50
M20	2.50	372.0	95.60	528.0	132.00
M22	2.50	519.0	118.00	722.0	164.00
M24	3.00	640.0	138.00	914.0	190.00
M30	3.50	1314.0	219.00	1817.0	303.00
M36	4.00	2297.0	319.00	3173.0	441.00

Metric Fine			PC 8.8		PC 10.9	
Diam	Pitch MM	Tap Drill	Torque Nm	Bolt Tension kN	Torque Nm	Bolt Tension kN
M8	1.00	7.00	24.0	14.8	34.0	21.1
M10	1.25	8.90	46.0	23.1	66.0	33.0
M12	1.25	10.50	83.0	34.7	119.0	49.7
M14	1.50	1.50	132.0	47.1	189.0	67.6

Nominal Length of Bolt	T = Thread Length
Up to 125mm	T = 2D + 6mm
Over 125, up to 200mm	T = 2D + 12mm
Over 200mm	T = 2D + 25mm
	Where D is the diameter



Do yourself a favour
ALWAYS ASK FOR ECLIPSE FASTENERS

Disclaimer: Whilst every effort has been made to ensure the accuracy of the information provided, Eclipse Fasteners (Aust) accepts no liability for any loss or damage either direct or consequential arising out of or in relation to the use or application of the product or information referred to herein.



UNIFIED HEXAGON BOLTS

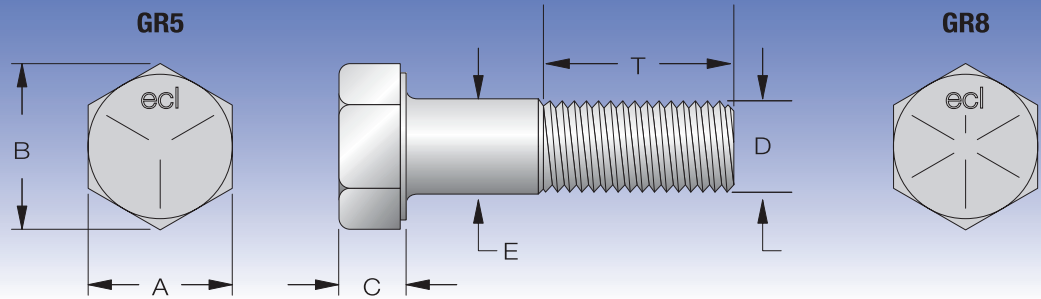

AS 2465-1981 • PRODUCT DIMENSIONS • IMPERIAL COARSE/FINE

D Diameter	Pitch TPI				A Across Flats		B Across Corners		Height C Head		E Shank Diameter	
	UNC	Tap Drill	UNF	Tap Drill	Max	Min	Max	Min	Max	Min	Max	Min
1/4	20	5.10	28	5.50	0.438	0.428	0.505	0.488	0.163	0.150	0.250	0.245
5/16	18	6.60	24	6.80	0.500	0.489	0.577	0.557	0.211	0.195	0.313	0.306
3/8	16	8.00	24	8.50	0.562	0.551	0.650	0.628	0.243	0.226	0.375	0.369
7/16	14	9.40	20	9.90	0.625	0.612	0.722	0.698	0.291	0.272	0.438	0.430
1 / 2	13	10.80	20	11.50	0.750	0.736	0.866	0.840	0.323	0.302	0.500	0.493
9/16	12	12.20	18	12.90	0.812	0.798	0.938	0.910	0.371	0.348	0.563	0.554
5/8	11	13.50	18	14.50	0.938	0.922	1.083	1.051	0.403	0.378	0.625	0.617
3/4	10	16.50	16	17.50	1.125	1.100	1.299	1.254	0.483	0.455	0.750	0.741
7/8	9	19.50	14	20.40	1.312	1.285	1.516	1.465	0.563	0.531	0.875	0.866
1	8	22.50	12	23.25	1.500	1.469	1.732	1.675	0.627	0.591	1.000	0.990
1.1/8	7	25.00	12	26.50	1.688	1.631	1.949	1.859	0.718	0.658	1.125	1.114
1.1/4	7	28.00	12	29.50	1.875	1.812	2.165	2.066	0.813	0.749	1.250	1.239
1.3/8	6	30.75	12	32.75	2.062	1.994	2.382	2.273	0.878	0.810	1.375	1.363
1.1/2	6	34.00	12	36.00	2.250	2.175	2.598	2.480	0.974	0.902	1.500	1.488
1.3/4	5	39.00			2.625	2.538	3.031	2.893	1.134	1.054	1.750	1.738
2	4.5	44.50			3.000	2.900	3.464	3.306	1.263	1.175	2.000	1.988

Nominal Length of Bolt	T = Thread Length
Up to 6 inches	$T = 2D + \frac{1}{4}$ Inch
Over 6 inches	$T = 2D + \frac{1}{2}$ inch
	Where D is the diameter

IMPERIAL COARSE/FINE

Diameter	SAE Grade 5				SAE Grade 8			
	UNC		UNF		UNC		UNF	
	Torque Ft.lbs	Bolt Tension lbs	Torque Ft.lbs	Bolt Tension lbs	Torque Ft.lbs	Bolt Tension lbs	Torque Ft.lbs	Bolt Tension lbs
1/4	7	1760	8	2010	10	2470	12	2820
5/16	15	2890	17	3180	21	4090	23	4510
3/8	27	4290	30	4840	38	6040	43	6820
7/16	43	5880	48	6560	61	8320	67	9230
1/2	66	7860	74	8840	92	11050	104	12480
9/16	94	10070	105	11240	133	14170	149	15860
5/8	130	12480	148	14170	183	17610	208	19950
3/4	231	18460	258	20600	326	26060	364	29120
7/8	373	25550	410	28100	525	36000	579	39700
1	558	33470	610	36600	787	47200	862	51700
1.1/8	688	36700	771	41100	1116	59500	1251	66700
1.1/4	971	46600	1075	51600	1573	75500	1744	83700
1.3/8	1272	55500	1448	63200	2063	90000	2349	102500
1.1/2	1690	67600	1900	76000	2738	109500	3083	123300

- Tightening Torque values indicated are for plain finished product in a lightly oiled condition.
- Theoretical induced bolt tensions at the torque value are equivalent to 65% of proof load.