

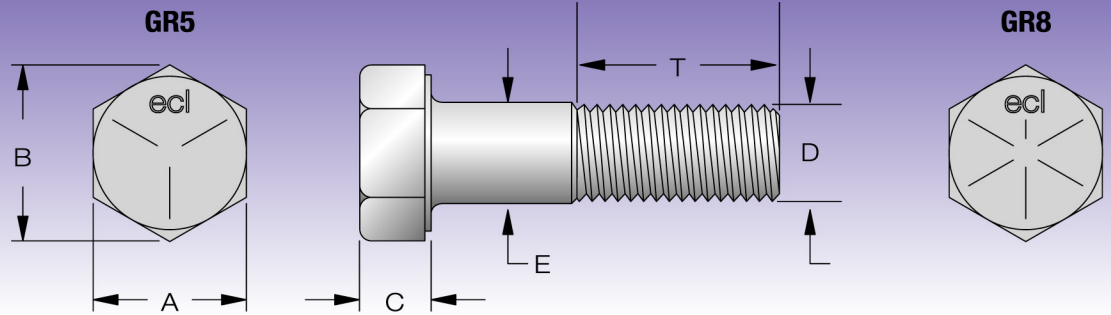

UNIFIED HEXAGON BOLTS



AS 2465-1981 • PRODUCT DIMENSIONS • IMPERIAL COARSE/FINE

D Diameter	Pitch TPI				A Across Flats		B Across Corners		Height C Head		E Shank Diameter	
	UNC	Tap Drill	UNF	Tap Drill	Max	Min	Max	Min	Max	Min	Max	Min
1/4	20	5.10	28	5.50	0.438	0.428	.0505	0.488	0.163	0.150	0.250	0.245
5/16	18	6.60	24	6.80	0.500	0.489	0.577	0.557	0.211	0.195	0.313	0.306
3/8	16	8.00	24	8.50	0.562	0.551	0.650	0.628	0.243	0.226	0.375	0.369
7/16	14	9.40	20	9.90	0.625	0.612	0.722	0.698	0.291	0.272	0.438	0.430
1 / 2	13	10.80	20	11.50	0.750	0.736	0.866	0.840	0.323	0.302	0.500	0.493
9/16	12	12.20	18	12.90	0.812	0.798	0.938	0.910	0.371	0.348	0.563	0.554
5/8	11	13.50	18	14.50	0.938	0.922	1.083	1.051	0.403	0.378	0.625	0.617
3/4	10	16.50	16	17.50	1.125	1.100	1.299	1.254	0.483	0.455	0.750	0.741
7/8	9	19.50	14	20.40	1.312	1.285	1.516	1.465	0.563	0.531	0.875	0.866
1	8	22.50	12	23.25	1.500	1.469	1.732	1.675	0.627	0.591	1.000	0.990
1.1/8	7	25.00	12	26.50	1.688	1.631	1.949	1.859	0.718	0.658	1.125	1.114
1.1/4	7	28.00	12	29.50	1.875	1.812	2.165	2.066	0.813	0.749	1.250	1.239
1.3/8	6	30.75	12	32.75	2.062	1.994	2.382	2.273	0.878	0.810	1.375	1.363
1.1/2	6	34.00	12	36.00	2.250	2.175	2.598	2.480	0.974	0.902	1.500	1.488
1.3/4	5	39.00	12	36.00	2.625	2.538	3.031	2.893	1.134	1.054	1.750	1.738
2	4.5	44.50	12	36.00	3.000	2.900	3.464	3.306	1.263	1.175	2.000	1.988

Nominal Length of Bolt	T = Thread Length
Up to 6 inches	$T = 2D + \frac{1}{4}$ Inch
Over 6 inches	$T = 2D + \frac{1}{2}$ inch
	Where D is the diameter

IMPERIAL COARSE/FINE

Diameter	SAE Grade 5				SAE Grade 8			
	UNC		UNF		UNC		UNF	
	Torque Ft.lbs	Bolt Tension lbs	Torque Ft.lbs	Bolt Tension lbs	Torque Ft.lbs	Bolt Tension lbs	Torque Ft.lbs	Bolt Tension lbs
1/4	7	1760	8	2010	10	2470	12	2820
5/16	15	2890	17	3180	21	4090	23	4510
3/8	27	4290	30	4840	38	6040	43	6820
7/16	43	5880	48	6560	61	8320	67	9230
1/2	66	7860	74	8840	92	11050	104	12480
9/16	94	10070	105	11240	133	14170	149	15860
5/8	130	12480	148	14170	183	17610	208	19950
3/4	231	18460	258	20600	326	26060	364	29120
7/8	373	25550	410	28100	525	36000	579	39700
1	558	33470	610	36600	787	47200	862	51700
1.1/8	688	36700	771	41100	1116	59500	1251	66700
1.1/4	971	46600	1075	51600	1573	75500	1744	83700
1.3/8	1272	55500	1448	63200	2063	90000	2349	102500
1.1/2	1690	67600	1900	76000	2738	109500	3083	123300

- Tightening Torque values indicated are for plain finished product in a lightly oiled condition.
- Theoretical induced bolt tensions at the torque value are equivalent to 65% of proof load.